



CHARLOTTE HISTORIC DISTRICT COMMISSION

CERTIFICATE OF APPROPRIATENESS

CERTIFICATE NUMBER: HDCADMRM-2018-00328

DATE: 21 June 2018

ADDRESS OF PROPERTY: 2003 Dilworth Road East

HISTORIC DISTRICT: Dilworth

TAX PARCEL NUMBER: 12111112

OWNER/APPLICANT: Kirk A. James

DETAILS OF APPROVED PROJECT: The project is the installation of a secondary walkway. The new walkway will be stepping stones to coordinate with an existing set of stone on the Ideal Way side of the house. The project also includes the installation of a new light fixture measuring approximately 8-feet in height from grade to the top of the fixture. See attached exhibits labeled, 'Site Plan – June 2018,' 'Walkway Design – June 2018,' and 'Light Fixture Design – June 2018.'

1. Applicable Policy & Design Guidelines and Approval Authority – Projects Eligible for Administrative Approval, page 2.6: Landscape and Site Features.
2. The applicable Policy & Design Guidelines for Sidewalks and Parking (page 8.2) and Lighting (page 8.11) have been met.

- This Certificate of Appropriateness (COA) indicates that this project proposal has been determined to comply with the standards and policies of the Charlotte Historic District Commission.
- Display the blue COA placard in a visible location along with any required permits.
- No other approvals are to be inferred.
- No demolition other than that specifically indicated on any attached plans is authorized under this approval.
- All work must be completed in accordance with all other applicable state and local codes.
- Any changes from or additions or deletions to the plans referenced herein will void this Certificate, and a new application must be filed with the Historic District Commission.

This Certificate is valid for a period of twelve (12) months from the date of issuance. Failure to obtain a building permit in that time will be considered as a failure to comply with the Certificate and the Certificate will become invalid. If a building permit is not required, then the approved work must be completed within twelve (12) months of the date of issuance of this Certificate. In either situation, the Certificate can be renewed for an additional twelve (12) months by Historic District Commission staff by written request within the first twelve (12) months from the date of issuance.

James Haden, Chairman

Staff

Site Plan June 2018



APPROVED

Charlotte
Historic District
Commission

Certificate of Appropriateness

HDCADM-2018-00328

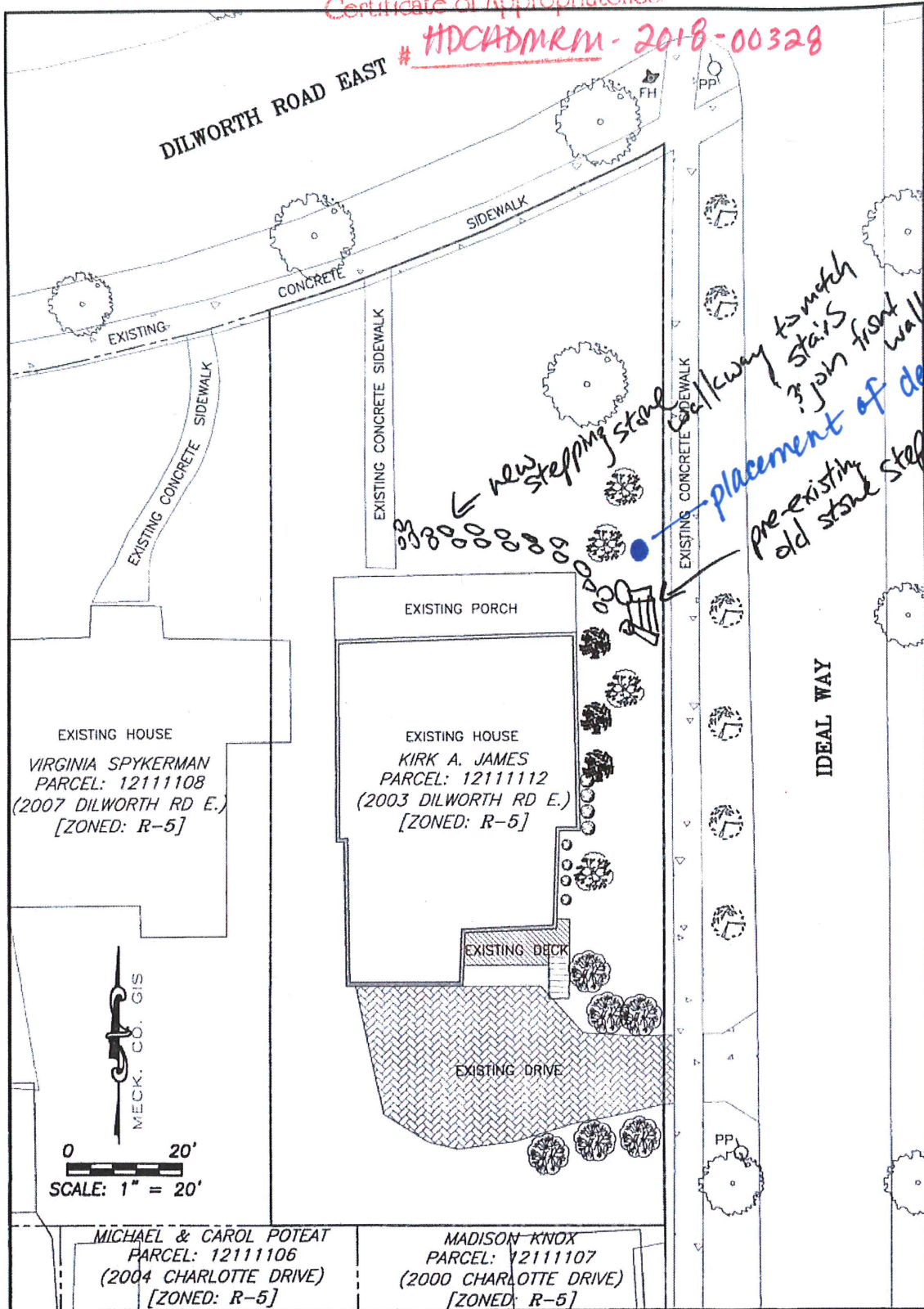



Walkway Design - June 2018



APPROVED

Charlotte
Historic District
Commission

Certificate of Appropriateness

HDCHDMM-2018-00328

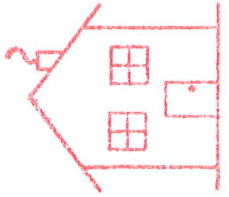

APPROVED

Charlotte
Historic District
Commission

Certificate of Appropriateness

HDCADM-2018-00328

Light Fixture Design June 2018

3:31 lanternscroll.com

3:33 lanternscroll.com

GIVE REVIEW / VIEW REVIEWS

Home / Shop / Post/Column Mount / Black Aluminum Pole

Home / Shop / Post/Column Mount / T-30

BLACK ALUMINUM POLE

T-30

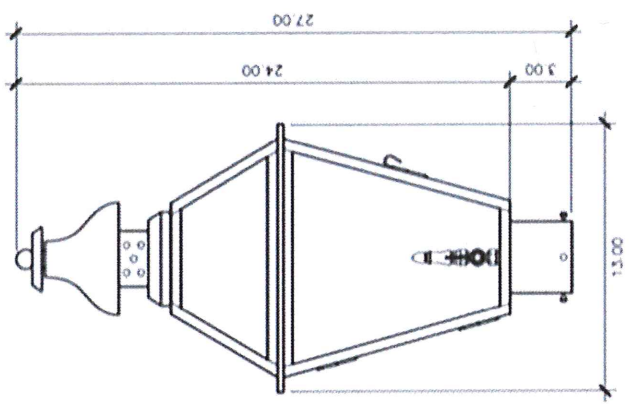
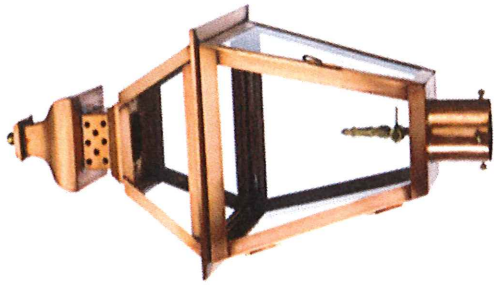

DIMENSION

Dimensions: 27h x 13w x 13d
 Post Collar Height: 3 inches
 Fits Standard Posts or Pier Mounts of 3 inches in Diameter

Download

