

# Rezoning Transportation Analysis

Petition Number: 2017-097

General Location Identifier: 14107104, 14107121, 14107122

**From:** Kelsie Anderson, PE  
[Kelsie.Anderson@charlottenc.gov](mailto:Kelsie.Anderson@charlottenc.gov)  
704-432-5492

**Reviewer:** Carlos Alzate  
calzate@charlottenc.gov  
704-432-0672

## Revision Log:

Date	Description
07-20-17	First Review

## General Review Information

The site is on Shopton Rd (minor thoroughfare) and is located in a center outside of Route 4. City CNIP bridge replacement project nearby.

---

CDOT's review of this rezoning petition is intended to ensure consistency with the Transportation Action Plan (TAP) which seeks to ensure that the City's transportation network supports current and future land uses and includes streets that provide safe and comfortable mobility for motorists, pedestrians, bicyclists, and transit users.

This document is primarily for communication to Planning Department staff as part of the overall City staff analysis of the rezoning petition and includes an overall summary of the case from a transportation perspective, information on trip generation, and resolved or outstanding site plan concerns. Additional advisory information about the driveway permit process is provided for information only.

---

Based on our review of the petition, we offer the following information for your consideration.

## Transportation Summary

To be provided prior to public hearing.

## Trip Generation

Scenario	Land Use	Intensity	Trip Generation (vehicle trips/day)	Source
Existing Use	Vacant	N/A	N/A	Petition
Entitlement with Current Zoning	Single Family (97.8 acres of R-3) Warehouse (10.6 acres of B-D)	93 dwellings 106K sf	3,200	General Guidance from Planning
Proposed Zoning	Warehouse	2M sf	7,120	Site Plan: 05-22-17

## Outstanding Issues

~~Strikeout~~ = Not an outstanding issue

- Traffic Study** A Traffic Impact Study/Transportation Technical Memorandum is needed for the complete review of this petition. TIS scope has been approved. CDOT has not yet received TIS for review. Coordination with NCDOT is intended. Further comments are anticipated once the study is submitted and reviewed.
- The petitioner should revise the site plan and conditional note(s) to show Shopton Rd Extension from Pinecrest Dr/Sirona Dr to Beam Rd as identified in the Airport Area Master Plan. 2-lane divided with appropriate bike and ped facilities.

# Rezoning Transportation Analysis

Petition Number: 2017-097

General Location Identifier: 14107104, 14107121, 14107122

- The petitioner should revise the site plan to show the proposed south most entrance aligning with the proposed Arrowood Rd-Shopton Rd Connector. 2-lane divided with appropriate bike and ped facilities.

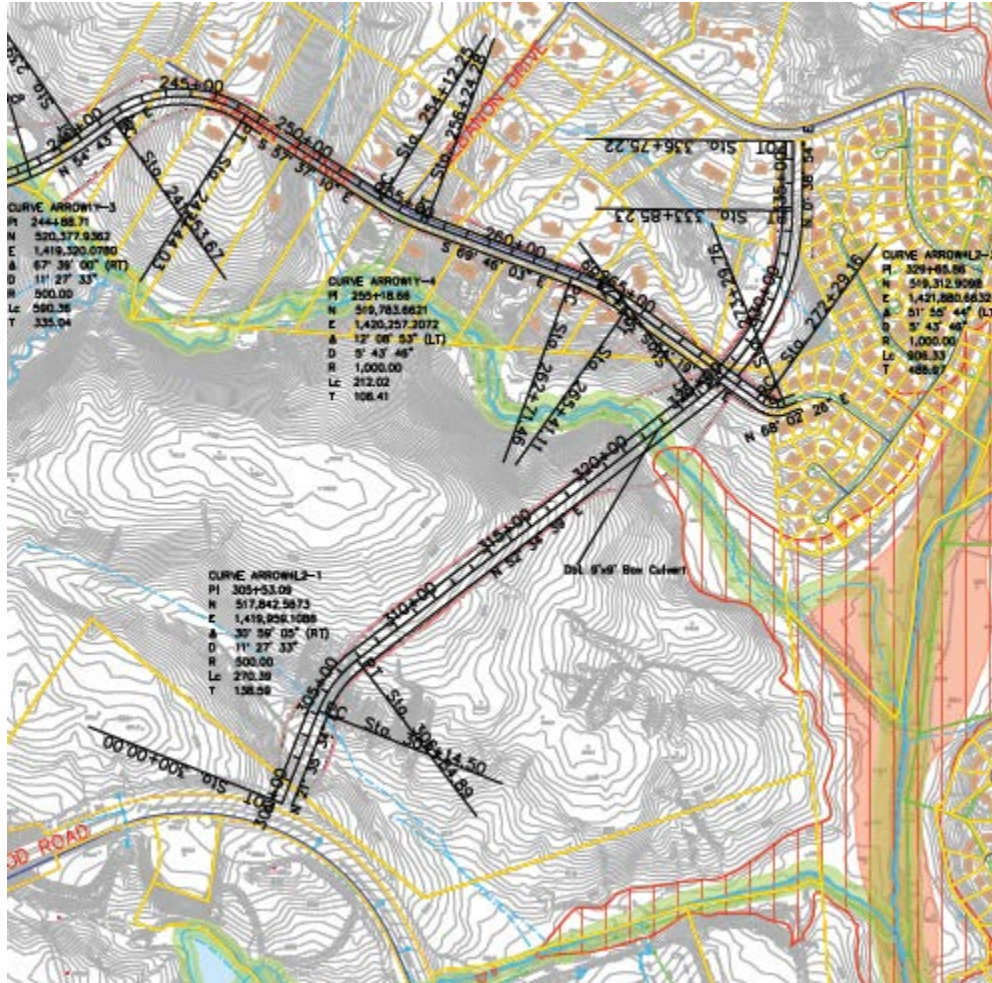

- The petitioner should revise the site plan to show 2.5 foot curb and gutter, 8 foot planting strip and 6 foot sidewalk on existing Shopton Rd. The back of curb location is 41 feet from centerline of Shopton Rd.
- The petitioner should revise the site plan to show dedication of right of way, fee simple, 57 feet from centerline of existing Shopton Rd to accommodate the envisioned future cross section.
- The Coffey Creek bridge on Shopton Rd is to be replaced as part of a CNIP project. Street improvements should tie in to anticipated cross section below. Contact Felix Obregon at 704-432-5729 to discuss project specifics and coordination, as needed.

# Rezoning Transportation Analysis

Petition Number: 2017-097

General Location Identifier: 14107104, 14107121, 14107122

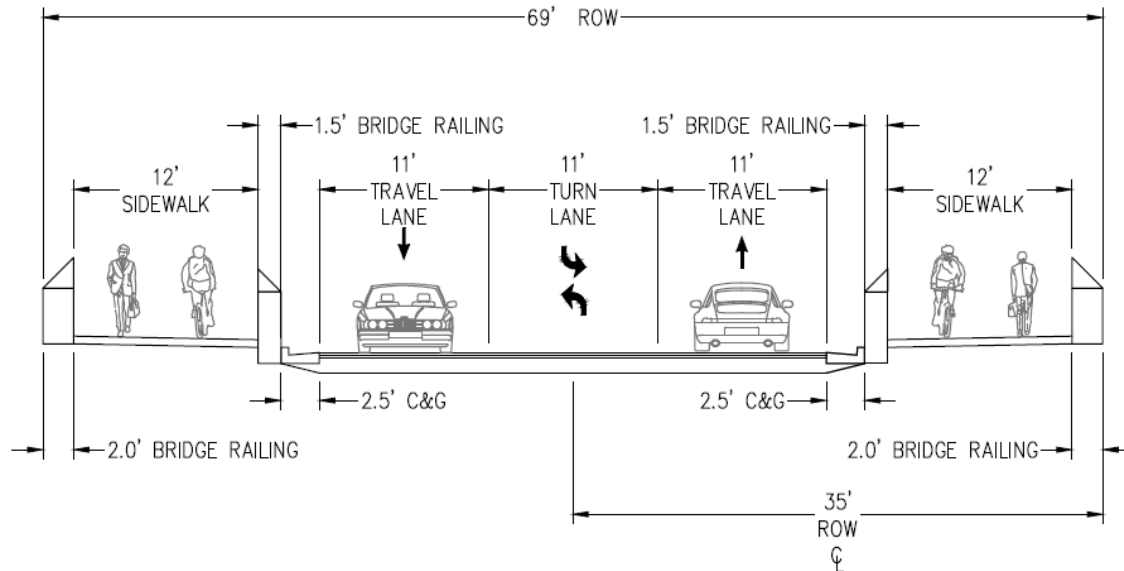

7. The petitioner should revise the site plan to show dedication of right of way for Coffee Creek Greenway. Contact County Parks and Rec to determine the amount of right of way needed.
8. The petitioner should revise the site plan to add a note specifying dedication and fee simple conveyance of all rights of way to the City before the site's first building certificate of occupancy is issued. CDOT requests right of way set at 2' behind back of sidewalk where feasible.
9. The petitioner should revise the site plan to add a note specifying all transportation improvements will be approved and constructed before the site's first building certificate of occupancy is issued or phased per the site's development plan.

## Advisory Information

The following are requirements of the developer that must be satisfied prior to driveway permit approval. We recommend that the petitioner reflect these on the rezoning plan as-appropriate.

1. According to the City of Charlotte's Driveway Regulations, CDOT has the authority to regulate/approve all private street/driveway and public street connections to the right-of-way of a street under the regulatory jurisdiction of the City of Charlotte.
2. Adequate sight triangles must be reserved at the existing/proposed street entrance(s). Two 35' x 35' sight triangles (and two 10' x 70' sight triangles on North Carolina Department of Transportation on NCDOT maintained streets) are required for the entrance(s) to meet requirements. All proposed trees, berms, walls, fences, and/or identification signs must not interfere with sight distance at the entrance(s). Such items should be identified on the site plan.
3. The proposed driveway connection(s) to public streets will require a driveway permit(s) to be submitted to CDOT (and the North Carolina Department of Transportation on NCDOT maintained streets) for review and approval. The exact driveway location(s) and type/width of the driveway(s) will be determined by CDOT during the driveway permit process. The locations of the driveway(s) shown on the site plan are subject to change in order to align with driveway(s) on the opposite side of the street and comply with City Driveway Regulations and the City Tree Ordinance.
4. All proposed commercial driveway connections to a future public street will require a driveway permit to be submitted to CDOT for review and approval.
5. Any fence or wall constructed along or adjacent to any sidewalk or street right-of-way requires a certificate issued by CDOT.

# **Rezoning Transportation Analysis**

**Petition Number: 2017-097**

*General Location Identifier: 14107104, 14107121, 14107122*

6. A Right-of-Way Encroachment Agreement is required for the installation of any non-standard item(s) (irrigation systems, decorative concrete pavement, brick pavers, etc.) within a proposed/existing City maintained street right-of-way by a private individual, group, business, or homeowner's/business association. An encroachment agreement must be approved by CDOT prior to the construction/installation of the non-standard item(s). Contact CDOT for additional information concerning cost, submittal, and liability insurance coverage requirements.